

Construction Notes

The following work shall be completed prior to lift installation procedure.

- 1) If required a suitably sized pit shall be excavated with a smooth and level finish. If no pit is required the installation area shall be clear of debris, smooth and level.
- 2) If required, the builder shall provide within building, supports for fixing enclosure in locations shown on General Assembly Drawing [sheet 1]
- 3) Upper threshold fixings will be used at time of installation.
- 4) A 100kg Push in / Pull out load (per fixing) shall be imposed on the building structure at guide fixing points to accommodate lift operation.

General Information

- 1) Assistance required with the off loading of equipment.
- 2) There shall be a clear access to the installation area.
- 3) As secured area shall be made available, adjacent to installation area for storage of tools and equipment.
- 4) Installation area shall be clear of debris and site personnel for the duration of the lift installation.
- 5) Builder shall provide hoardings / barriers to protect the upper landing area for duration of the lift installation
- 6) Installation area must be adequately illuminated
- 7) 110v power supply shall be available for the use of power tool etc.
- 8) Facilities for both washing and first aid care must be readily available.

NOTES:

- 1) The maximum headroom required is a function of the basic floor to floor dimension. For additional information contact Axess 4 All.
- 2) The door/gate entry and exit points may be amended to either a same side or adjacent entry layout. All adjacent configurations shall have large size platforms.
- 3) This data sheet is intended for information purposes only. Axess 4 All reserve the right to amend any design aspects without prior notice.
- 4) Additional fixings may be required on the mast side for rigidity on the units with a total travel above 1400mm. Alternative arrangements to be discussed with Axess 4 All if it is not possible to fix to the building structure at the point.

Drawn by	S. Dewar	Date	07.07.08
Checked by	S. Pawley	Date	07.07.08
Sheet	ONE	of	TWO

Site Name :	A3000-10 Open Through Upper Level Gate 900 x 1400 Platform	Ref No. :	Typical 10
-------------	---	-----------	------------

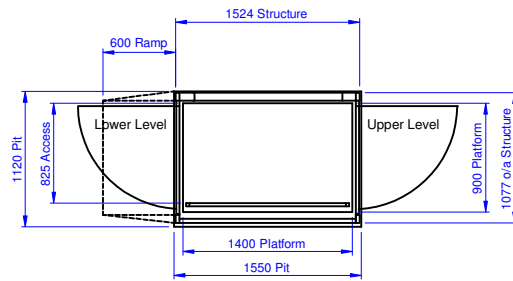

PLAN VIEW

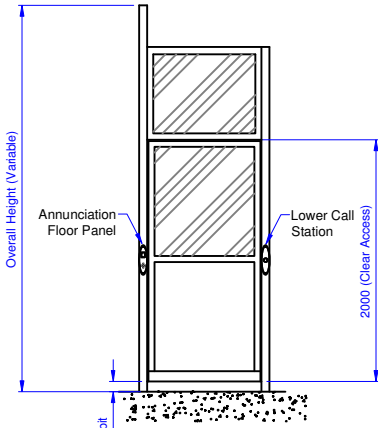

VIEW ON LOWER LEVEL

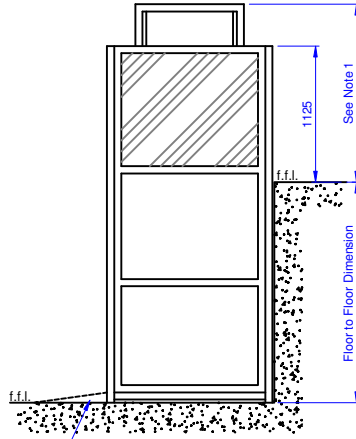

SIDE ELEVATION

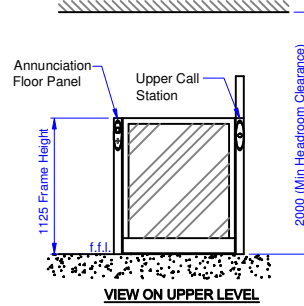

VIEW ON UPPER LEVEL

TYPICAL ONLY DRAWINGS
 NOT TO BE USED FOR
 CONSTRUCTION PURPOSES

Access ramp provided if no pit available

Drawn by	S. Dewar	Date	07.07.08
Checked by	S. Pawley	Date	07.07.08
Sheet	ONE	of	TWO

Site Name :	A3000-10 Open Through Upper Level Gate 900 x 1400 Platform	Ref No. :	Typical 10
-------------	---	-----------	------------

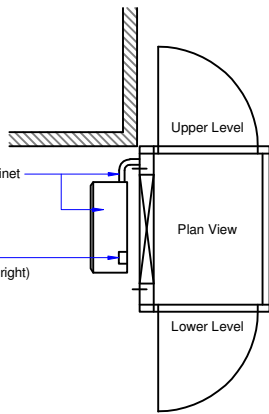

DETAIL OF UPPER & LOWER LEVELS
 (the details to be confirmed)

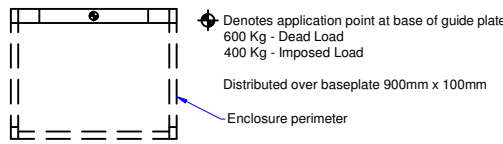

ENCLOSURE LOADING DETAILS

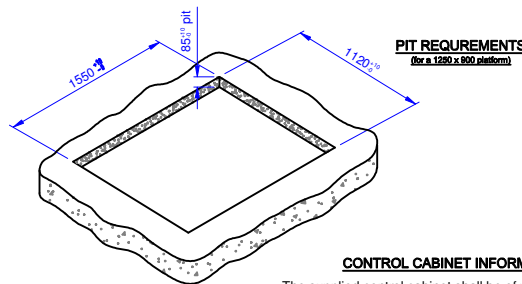

PIT REQUIREMENTS
 (for a 1250 x 800 platform)

LIFT PIT CONSIDERATIONS
 IF THE LIFT ENCLOSURE IS TO BE PLACED IN AN EXTERIOR POSITION, THE BUILDER MUST ENSURE ADEQUATE DRAINAGE IN THE LIFT PIT AREA.

CONTROL CABINET INFORMATION

The supplied control cabinet shall be of weather proof construction to IP65 standard and shall be mounted in a suitable position not more than 5m from the guide base plate

The final position of the control cabinet shall be agreed before lift installation commences unless shown on site specific general arrangement layout

There needs to be adequate lighting and access to the control cabinet for maintenance and emergency procedures to be carried out.

There may be a necessity for the client to chase one sub-surface conduit run from the guide side of the lift enclosure to the control cabinet. (min size = 75mm SQ)

Electrical Information

- 1) Provision must be made for a dedicated 240v AC 13 amp supply terminating in a 13 amp switched fused locale isolator.
- 2) Provide a twin socket adjacent to installation for use of power tools and light lead extensions for maintenance purposes.
- 3) Ensure Lighting at both floor levels is adequate and is not less than 50 Lux when measured at each entrance level.

Electrical Specification

- 1) Contract Load 400 Kg
 - 2) Platform Speed (travel upto 1400mm) 0.08 m/sec
 - 3) Platform Speed (travel over 1400mm) 0.10 m/sec
 - 4) Control System Voltage 24v DC
 - 5) Power Supply 240v AC 13 Amp
- Electrical Data**
- 1) Motor 0.55 kW
 - 2) Starting Current 18 Amps
 - 3) Running Current 4.5 Amps

TYPICAL ONLY DRAWINGS
 NOT TO BE USED FOR
 CONSTRUCTION PURPOSES

Drawn by	S. Dewar	Date	07.07.08
Checked by	S. Pawley	Date	07.07.08
Sheet	TWO	of	TWO

Site Name :	A3000-10 Open Through Upper Level Gate 900 x 1400 Platform	Ref No. :	Typical 10
-------------	---	-----------	------------

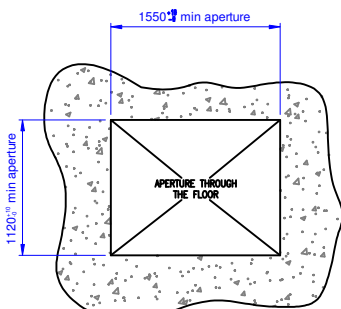

The aperture through the upper floor should be formed directly above the location of the lift in accordance with the drawing above and must be perfectly aligned

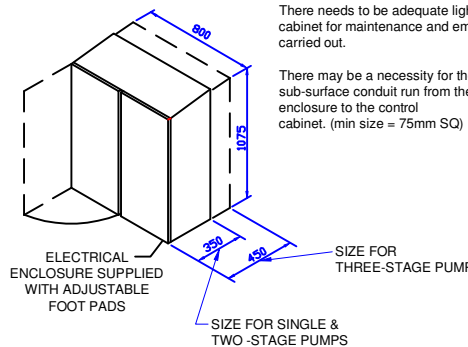

ELECTRICAL ENCLOSURE SUPPLIED WITH ADJUSTABLE FOOT PADS

SIZE FOR THREE-STAGE PUMP

SIZE FOR SINGLE & TWO-STAGE PUMPS